

A1

黑白

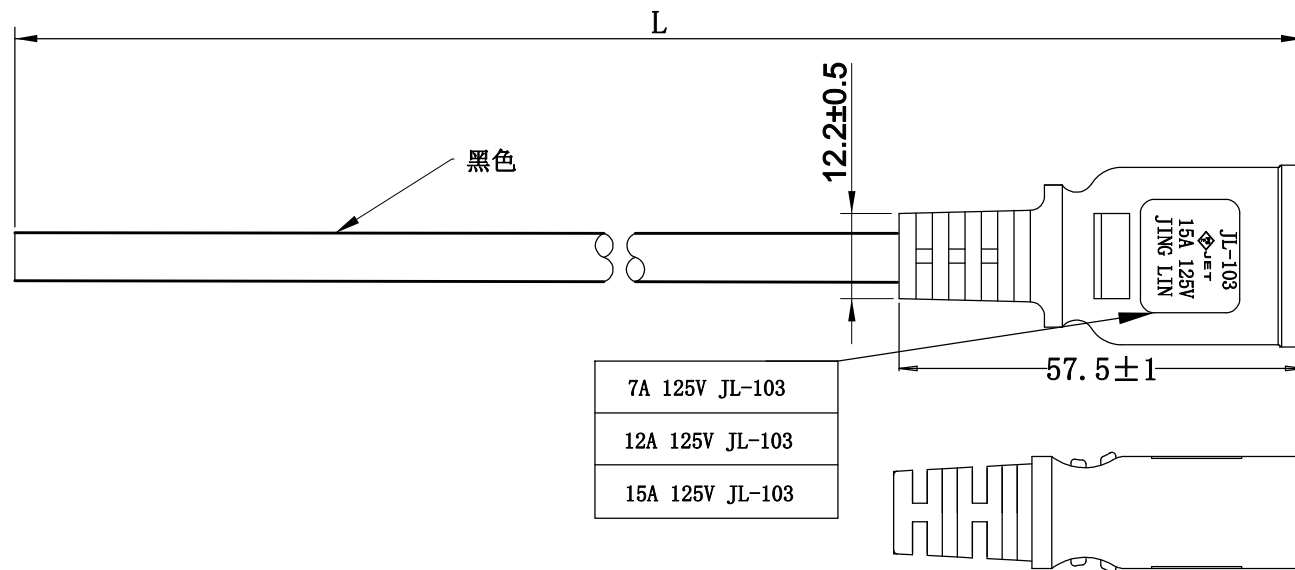

7A 125V JL-103
12A 125V JL-103
15A 125V JL-103

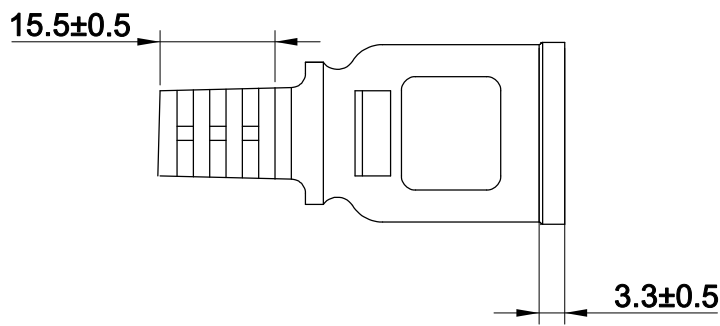

B1

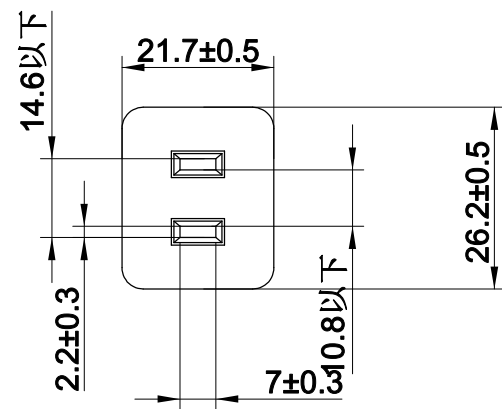

順番	適合電線	ソケット品番	技術基準	導体導線	電線寸法
1	VCTF 0.75mm ² /2C	JL-103	7A 125V	30本/0.18AS	6.8±0.2
2	VCTF 1.25mm ² /2C	JL-103	12A 125V	50本/0.18AS	7.4±0.2
3	VCTF 1.8mm ² /2C	JL-103	15A 125V	72本/0.18AS	7.7±0.2
4	VCTF 2.0mm ² /2C	JL-103	15A 125V	41本/0.25AS	8.1±0.2

線材印字:

<PS>E JET 6879-12009-1001 VCTF 2X0.75mm² JINGLIN LF

<PS>E JET 6879-12009-1001 VCTF 2X1.25mm² JINGLIN LF

<PS>E JET 6879-12009-1001 VCTF 2X1.8mm² JINGLIN LF

<PS>E JET 6879-12009-1001 VCTF 2X2.0mm² JINGLIN LF

QICHUANG INT'L CO., LIMITED

顧客 CUSTOMER		單位 UNIT:	mm
部材品番 PART. NO.	JL-103 + VCTF - M	比例 TITLE	Free
製品名称 TITLE	2PソケットVCTF電源線 7A 12A 15A 125V M型	日期 DATE	23. 12. 10
製品品番 DWG. NO.	JL-103 + VCTF-2C-M-L	製作 DWG BY:	
図番 VERSIONS		確認 CHE BY:	
H P	www.qcledlight.com		